



Fire Pump Packaged Solutions



Single Diesel & Electric Booster Pumps

Over the last 20 years, Aline Group has worked with some of the largest commercial and property developers in Australia to provide the perfect fire pump solutions for their needs. Aline Group manufacture and design in house so can provide solutions that meet custom specifications between 10 litres and 300 litres a second and 500kPa and 2600kPa.



Aline Group offers a wide range of Fire Pumpsets all of which are made to the highest industry standards.

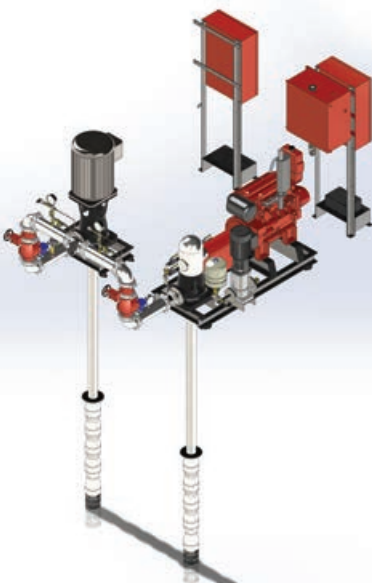

Diesel and electric deep well turbine pump

Dual Diesel and Electric Booster Pumps to suit Fire Hydrant Systems, Fire Sprinkler Systems, and Drencher Pump Services

Single Diesel & Electric Booster Pumps with a broad scope of options, including weatherproof pump enclosures, galvanised baseplates and skid packages complete with suction/relief valve/discharge

Electric Hydrant, Sprinkler and Drencher Pumps available with Star, Soft Start, DOL, Delta, and Variable speed drive options

Diesel & Electric Deep-Well Turbine Pumps with diesel engine drivers that come in both air cooled and water cooled configurations

Aline Group has provided fire pump solutions to the construction and plumbing industry all over Australia. Below are some of the projects we have worked on.



Aldi Distribution Centre – Regency Park SA

This project consisted of the construction of the warehouse and distribution centre. After careful consideration of the projects needs Aline Group provided a Dual 275kW Diesel AS2941 2013 Compliant Fire pump. This was successfully installed and commissioned.



Bankstown Airport - NSW

This project consisted of the construction of a warehouse to accommodate aviation equipment. After review and analysis of the requirements Aline Group designed and supplied a Dual Diesel Packaged Fire Pump system capable of the requirements outlined by the fire protection contractor.



BMA Blackwater Coal Mine - QLD

This project involved designing and supplying Diesel and Electric Fire Pumps compliant with the Australian Standards but also the Mining Standards and Specifications of the BMA Blackwater Coal Mine. The Fire pumps were part of the asset protection systems on the mine.



IKEA Majura - ACT

IKEA Majura ACT is a single storey bulky goods building of 25,800sqm with retail components, restaurant, warehouse and amenities. The project included associated car parking for 819 vehicles. Aline Pumps were awarded the supply package of a Triplex Fire Pump System using Cummins Engines and Tornatech control panels.



Wagga Wagga Base Hospital Redevelopment - NSW

During the redevelopment of the Wagga Wagga Base Hospital Aline Group consulted with the project team to develop a plan specific to the projects requirements. After careful planning Aline Pumps supplied a Diesel and Electric Fire Pump Package.



Moorebank Units Relocation - NSW

Thirteen Defence units and four allied facilities relocated from a Commonwealth owned Defence occupied site at Moorebank to Holsworthy Barracks. Aline Group worked closely with the project team to provide a plan tailored to the specific requirements of the project. After Careful consideration Three Super Titan Pumpsets coupled to Cummins Diesel Engines were specified. The system was successfully installed and commissioned.



Fair Haven Village Maryborough - QLD

The project involved the construction of approximately 100 independent living units. Aline Group worked closely with the project team to develop a cost effective solution to their fire pump needs. After consideration of the projects needs Aline Group provided two Fire 35kW Diesel Hydrant Pumps in a weather resistant enclosure. The pumpset and enclosure was installed and commissioned.

Aline Group Overview

Aline Group is one of the leading providers of pump systems within Australia's construction and plumbing industry. We have been offering professional and expert services since our establishment in 1995, and can assist from the manufacturing stage with custom solutions right through to after sales maintenance needs.



E: pumps@alinepumps.com
www.alinepumps.com

1800 018 999

Head Office: 17 Burns Road Heathcote NSW 2233
Brisbane: Unit 2, 43 Proprietary St Tingalpa QLD 4173

Aline Group Pty Ltd ABN 61 604 961 953